

JVC

SERVICE MANUAL

SYSTEM CONTROLLER

RM-RE9000



Area Suffix
 E Continental Europe

Contents

Safety Precautions 1-2
 Adjustment method 1-3
 Description of major ICs 1-6~8

Safety Precautions

1. This design of this product contains special hardware and many circuits and components specially for safety purposes. For continued protection, no changes should be made to the original design unless authorized in writing by the manufacturer. Replacement parts must be identical to those used in the original circuits. Services should be performed by qualified personnel only.
2. Alterations of the design or circuitry of the product should not be made. Any design alterations of the product should not be made. Any design alterations or additions will void the manufacturer's warranty and will further relieve the manufacture of responsibility for personal injury or property damage resulting therefrom.
3. Many electrical and mechanical parts in the products have special safety-related characteristics. These characteristics are often not evident from visual inspection nor can the protection afforded by them necessarily be obtained by using replacement components rated for higher voltage, wattage, etc. Replacement parts which have these special safety characteristics are identified in the Parts List of Service Manual. Electrical components having such features are identified by shading on the schematics and by (Δ) on the Parts List in the Service Manual. The use of a substitute replacement which does not have the same safety characteristics as the recommended replacement parts shown in the Parts List of Service Manual may create shock, fire, or other hazards.
4. The leads in the products are routed and dressed with ties, clamps, tubings, barriers and the like to be separated from live parts, high temperature parts, moving parts and/or sharp edges for the prevention of electric shock and fire hazard. When service is required, the original lead routing and dress should be observed, and it should be confirmed that they have been returned to normal, after re-assembling.

5. Leakage current check (Electrical shock hazard testing)

After re-assembling the product, always perform an isolation check on the exposed metal parts of the product (antenna terminals, knobs, metal cabinet, screw heads, headphone jack, control shafts, etc.) to be sure the product is safe to operate without danger of electrical shock.

Do not use a line isolation transformer during this check.

- Plug the AC line cord directly into the AC outlet. Using a "Leakage Current Tester", measure the leakage current from each exposed metal parts of the cabinet, particularly any exposed metal part having a return path to the chassis, to a known good earth ground. Any leakage current must not exceed 0.5mA AC (r.m.s.).

● Alternate check method

Plug the AC line cord directly into the AC outlet. Use an AC voltmeter having, 1,000 ohms per volt or more sensitivity in the following manner. Connect a 1,500 Ω 10W resistor paralleled by a 0.15 μ F AC-type capacitor between an exposed metal part and a known good earth ground. Measure the AC voltage across the resistor with the AC voltmeter.

Move the resistor connection to each exposed metal part, particularly any exposed metal part having a return path to the chassis, and measure the AC voltage across the resistor. Now, reverse the plug in the AC outlet and repeat each measurement. Any voltage measured must not exceed 0.75 V AC (r.m.s.). This corresponds to 0.5 mA AC (r.m.s.).

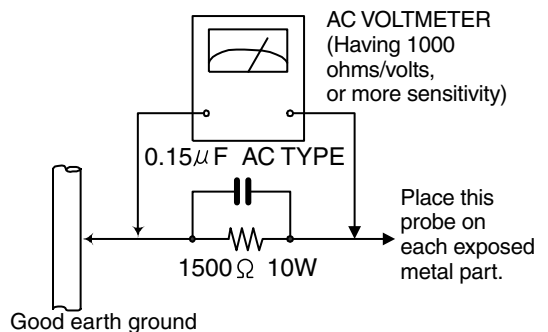

Warning

1. This equipment has been designed and manufactured to meet international safety standards.
2. It is the legal responsibility of the repairer to ensure that these safety standards are maintained.
3. Repairs must be made in accordance with the relevant safety standards.
4. It is essential that safety critical components are replaced by approved parts.
5. If mains voltage selector is provided, check setting for local voltage.

CAUTION

Burrs formed during molding may be left over on some parts of the chassis. Therefore, pay attention to such burrs in the case of preforming repair of this system.

In regard with component parts appearing on the silk-screen printed side (parts side) of the PWB diagrams, the parts that are printed over with black such as the resistor (■), diode (▣) and ICP (●) or identified by the " Δ " mark nearby are critical for safety.

When replacing them, be sure to use the parts of the same type and rating as specified by the manufacturer. (Except the JC version)

Disassembly method

■ Removing the rear cover (See Fig.1 to 3)

1. Remove the four screws **A** on the front with a hexagon wrench.
2. Place the reverse side of the set upward.
3. After taking off the cushions from the four places, remove the four screws **B** at the inside of the rear cover.
4. Remove the screw **B'** at the inside of the battery cover.
5. Remove the rear cover and the front panel assembly. (Because they should have been tightly engaged, remove them with due care.)
6. Remove the battery holder board assembly from the rear cover by pulling it up.

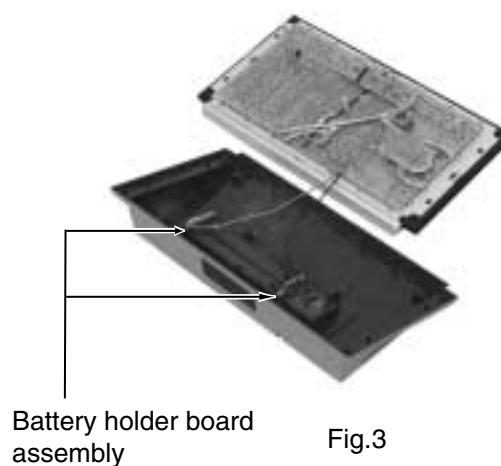
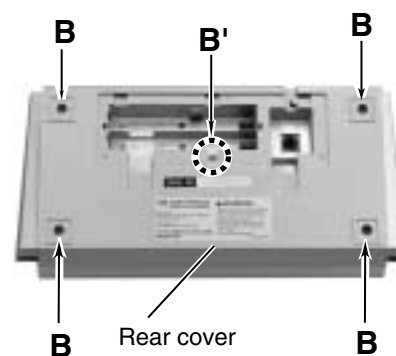
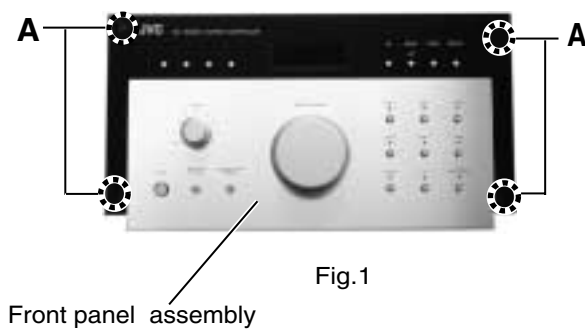

■ **Removing the remote controller transmission board assembly (See Fig.4)**

1. Remove the rear cover.
2. Remove the two screws **C** attaching the remote controller transmission board assembly.
3. Remove the connector CN201 connecting the main board assembly to the remote controller transmission board assembly.

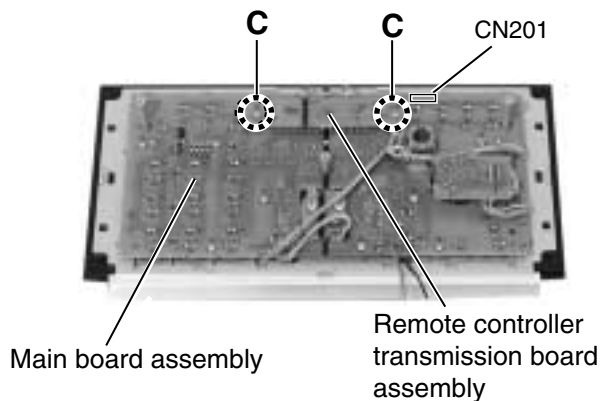

Fig.4

■ **Removing the main board assembly (See Fig.5 to 7)**

1. Remove the rear cover.
2. Remove the remote controller transmission board assembly.
3. After taking off the screws **D** & **E** attaching the volume knob and the rotary switch, remove their knobs.
4. After taking off the nut **F** attaching the volume board assembly with a box-type driver, remove the volume board assembly.
5. After taking off the nut **G** attaching the rotary switch board assembly with a box-type driver, remove the rotary switch board assembly.
6. Remove the fourteen screws **H** attaching the main board assembly.
7. Remove the connector CN103 connecting the main board assembly to the volume board assembly, and the connector CN301 connecting the main board assembly to the rotary switch board assembly, respectively.

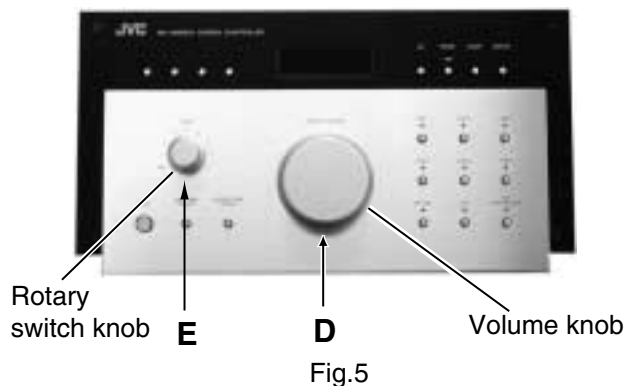

Fig.5

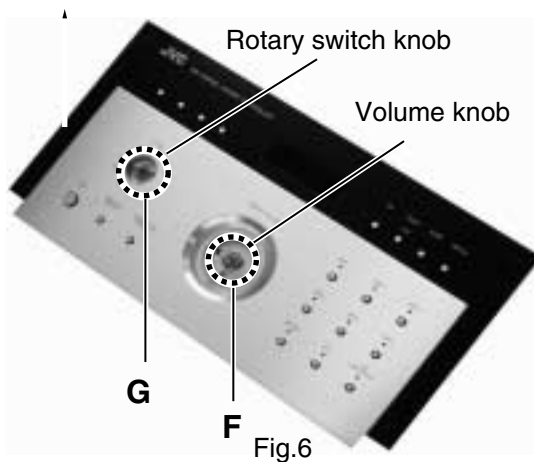

Fig.6

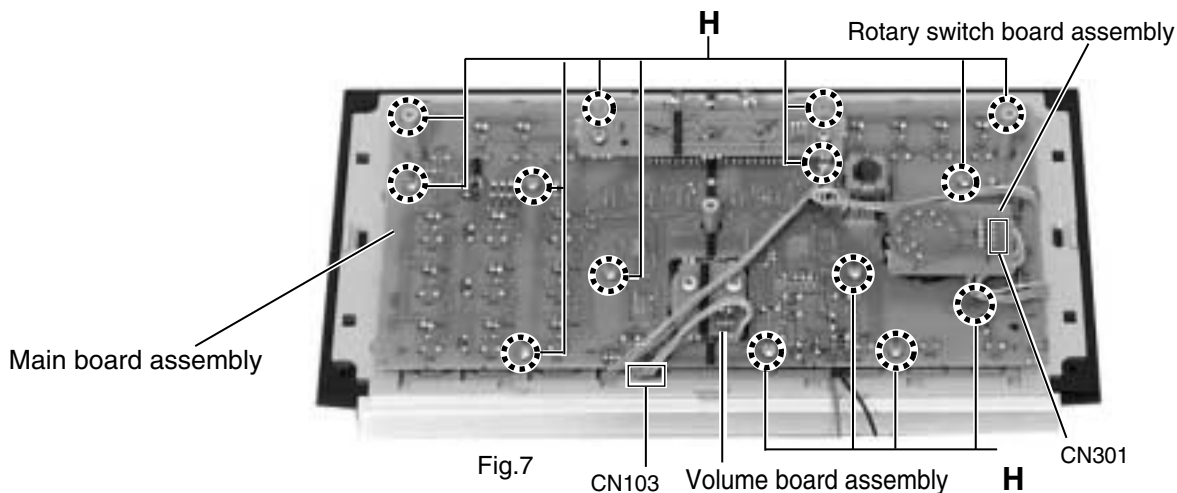

Fig.7

■ Removing the modular jack board assembly (See Fig.8)

1. Remove the rear cover.
2. Remove the remote controller transmission board assembly.
3. Remove the main board assembly.
4. Remove the two screws **I** attaching the modular jack board assembly.
5. Remove the connector CN501 connecting the main board assembly to the connector terminal board assembly.

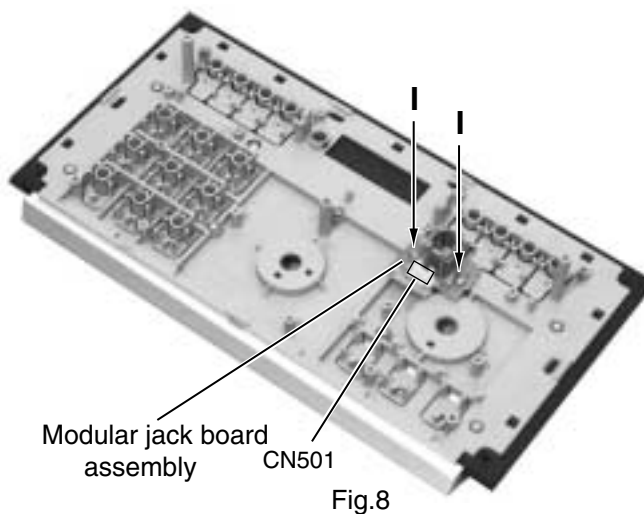

Fig.8

■ Removing the switch board (See Fig.9)

1. Remove the rear cover.
2. Remove the remote controller transmission board assembly.
3. Remove the main board assembly.
4. Remove the modular jack board assembly.
5. Remove the seven screws **J** attaching the switch board.
6. Remove the board by lifting it.

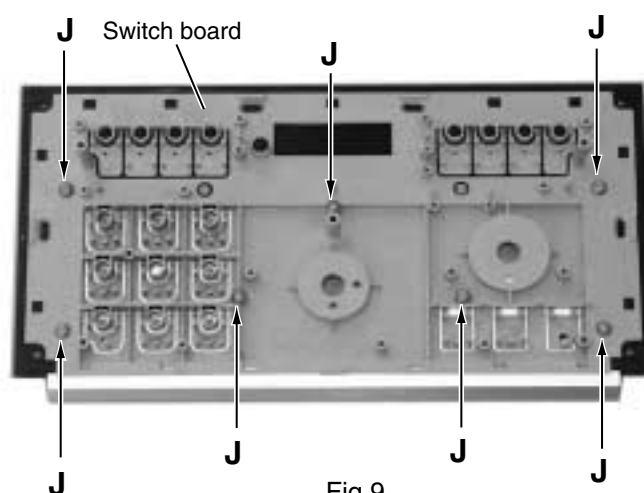

Fig.9

■ Removing the top panel (See Fig.10)

1. Remove the rear cover.
2. Remove the remote controller transmission board assembly.
3. Remove the main board assembly.
4. Remove the modular jack board assembly.
5. Remove the board.
6. Remove the two screws **K** attaching the lens and the top panel.

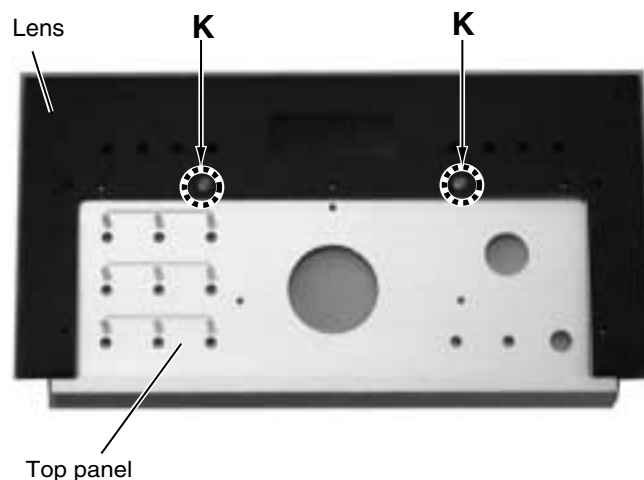

Fig.10

■ Reminder when the top panel is reassembled

1. When the top panel is reassembled, use the screws with the specified size (M3x8mm) without fail (Screws marked **K**).
Using longer screws may damage the top panel and cause the top panel unstable.

Description of major ICs

■ MN101CP117(IC101) : System controller

1.Pin layout

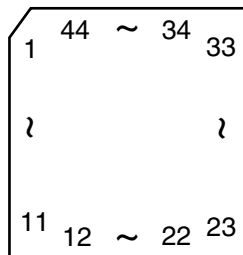

2.Pin function

Pin No.	Symbol	Function	I/O	Pin No.	Symbol	Function	I/O
1	KY13	Key input 8	I	23	CK1	7segment circuit clock 1	O
2	ROT1	Rotary output 1	O	24	LATCH1	7segment circuit latch output 1	O
3	ROT2	Rotary output 2	O	25	RST1	7segment circuit latch reset 1	O
4	ROT3	Rotary output 3	O	26	SIN1	Output data 1	O
5	ROT4	Rotary input 1	I	27	WAKE	Wake	I
6	ROT5	Rotary input 2	I	28	KY2	Key input 2	I
7	ROT6	Rotary input 3	I	29	KY3	Key input 3	I
8	N.C	GND	I	30	KY4	Key input	I
9	N.C	GND	I	31	KY5	Key output 1	O
10	VOL1	Volume input 1	I	32	KY6	Key output 2	O
11	VOL2	Volume input 2	I	33	CK2	LED circuit clock 2	O
12	AD	AD input	I	34	LATCH2	LED circuit latch output 2	O
13	VDD	2.0V~5.0V Supply		35	RST2	LED circuit reset 2	O
14	OSC2	clock output	O	36	SIN2	LED circuit data output 2	O
15	OSC1	clock input	I	37	KY7	Key output 3	O
16	VSS	0.0V		38	KY8	Key output 4	O
17	NC	—————		39	RST	Reset	I
18	SDATO	Serial output data	O	40	MMOD	GND	I
19	BRI	Blight adjustment	O	41	KY9	Key output 5	O
20	SCLK	Serial clock	O	42	KY10	Key input 5	I
21	KY1	Key input 1	O	43	KY11	Key input 6	I
22	RMOUT	Remocon output	O	44	KY12	Key input 7	I

■ TC74VHC123AF-X(IC112) :Shift register for relay control

1. Pin layout

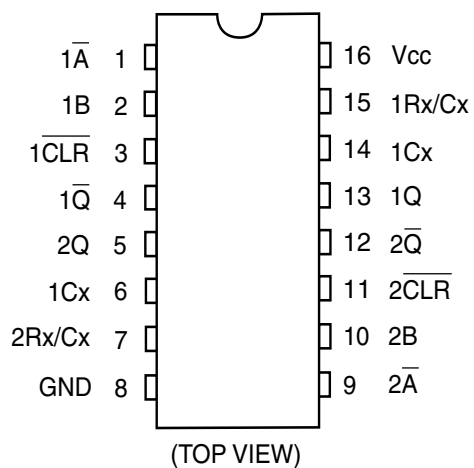

2. Block diagram

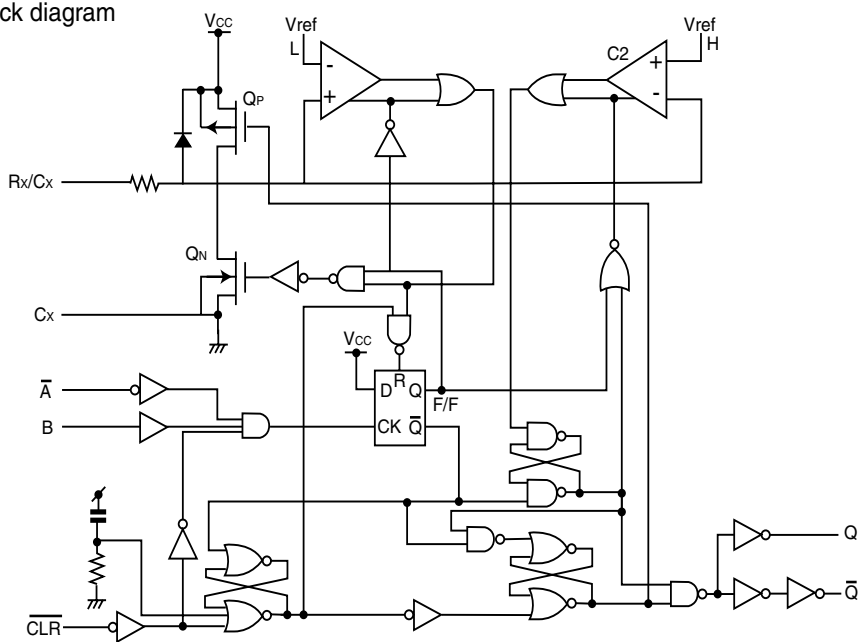

3. Timing diagram

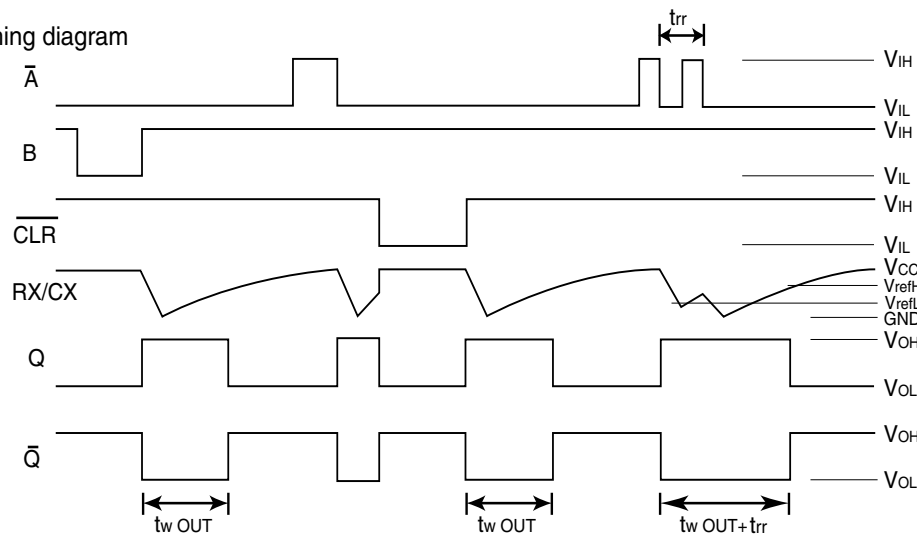

■ TC74VHC08F-X (IC112) :Data line buffer

1. Pin. layout

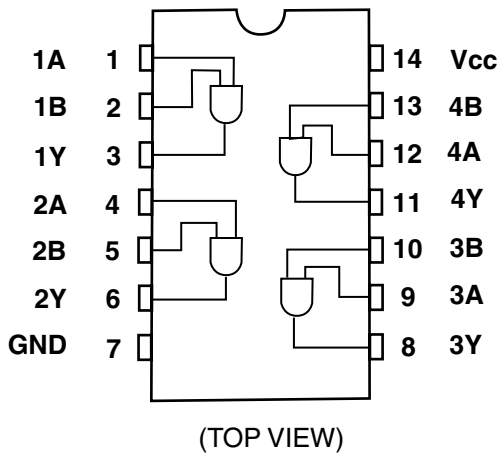

2. True table

A	B	Y
L	L	L
L	H	L
H	L	L
H	H	H

X : Don't Care

< MEMO >

Block diagram

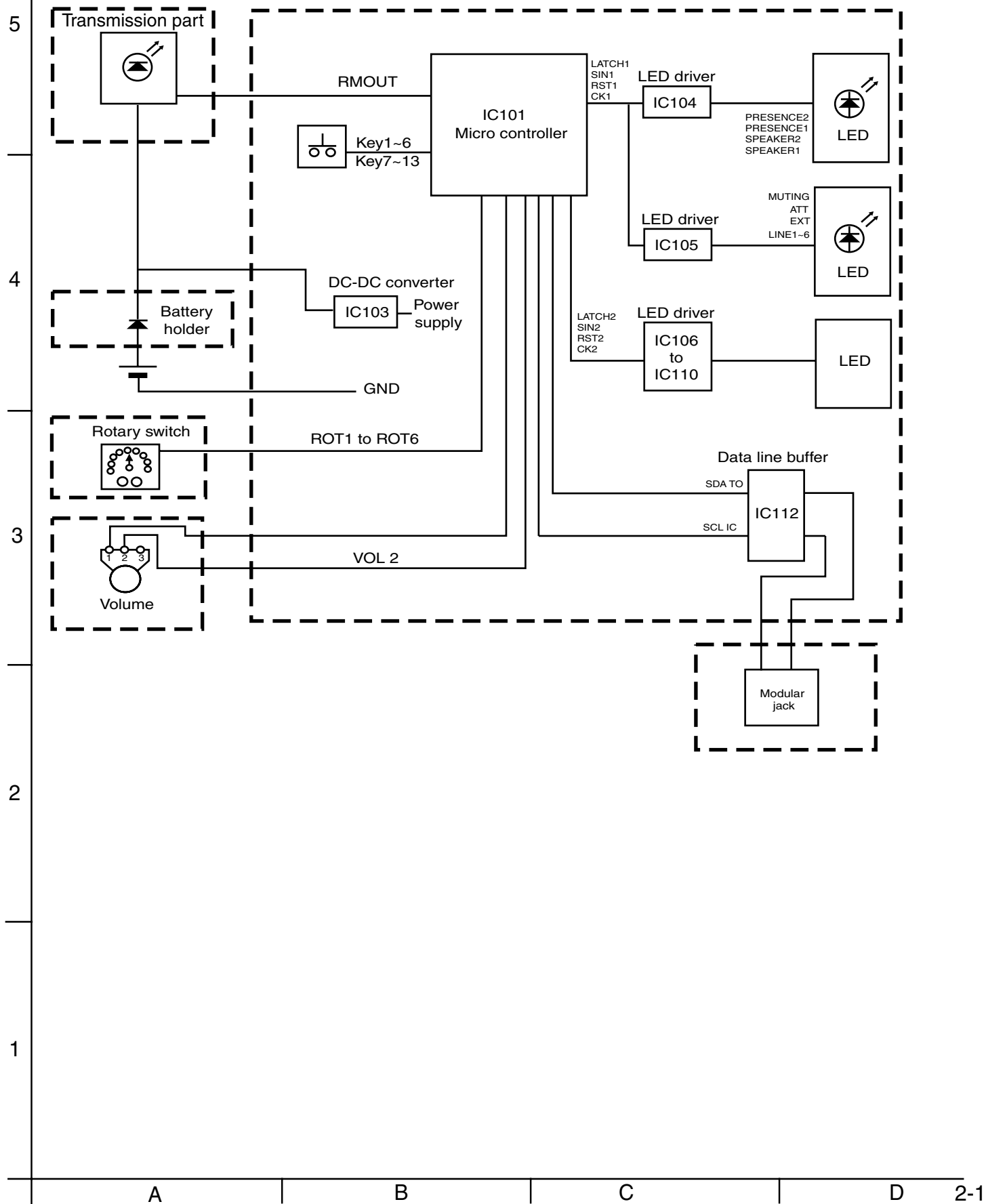

< MEMO >

Standard schematic diagram

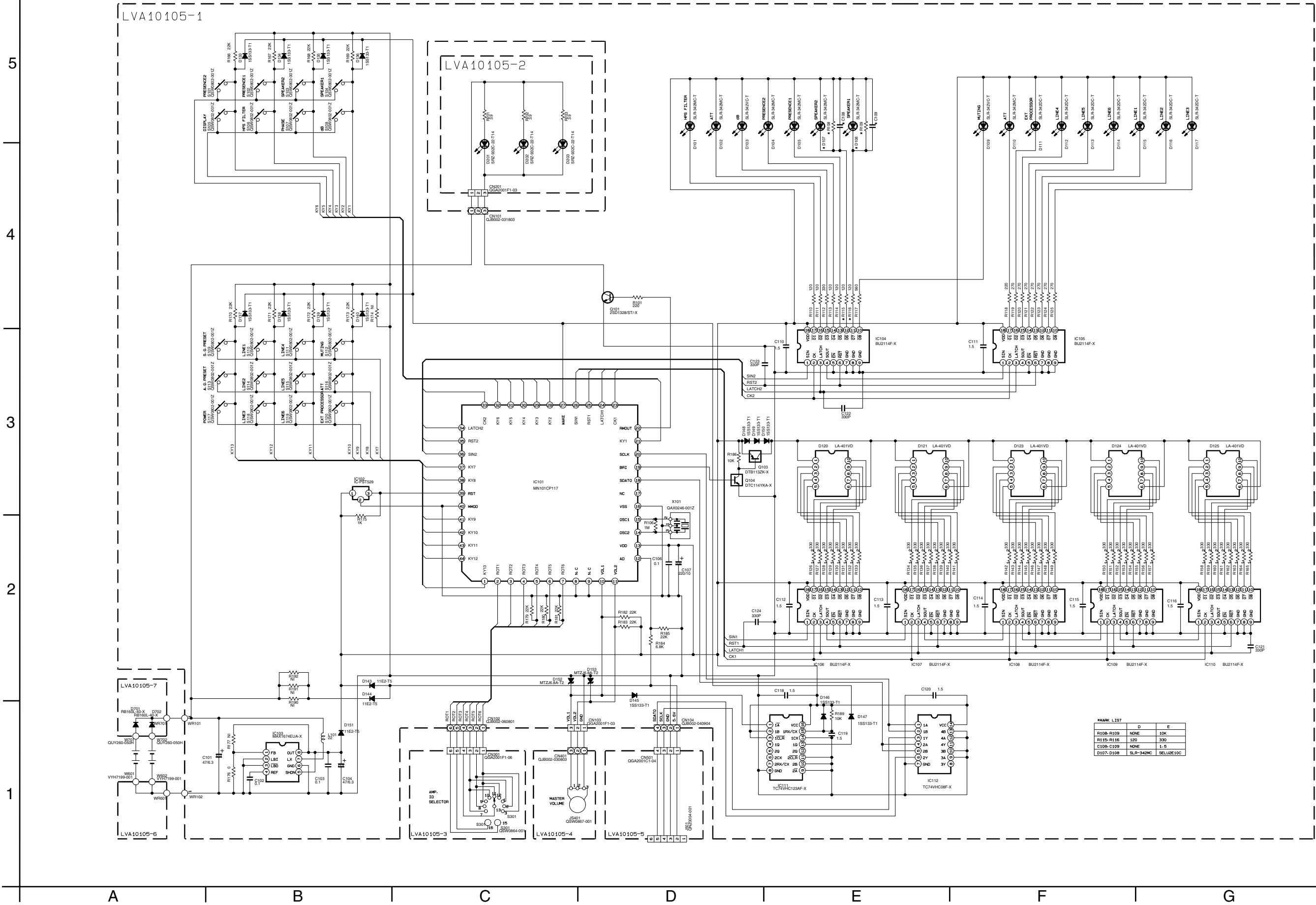

Printed circuit boards

■ Main board (Front side)

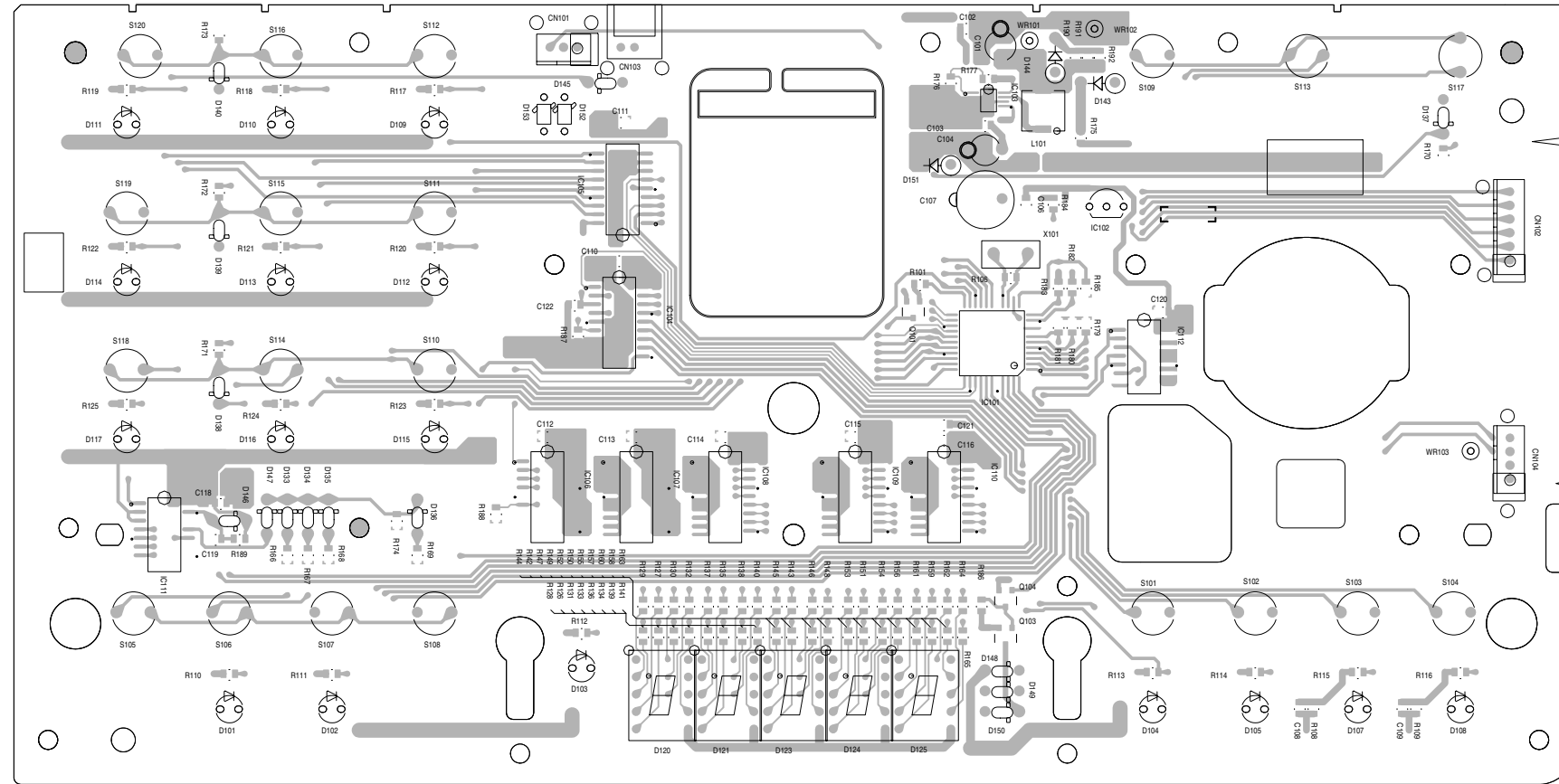

■ Remote controller transmission board

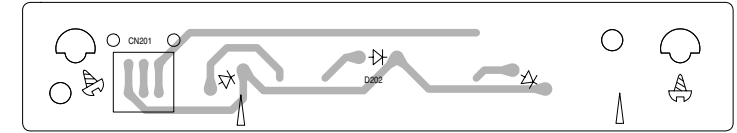

■ Battery holder board

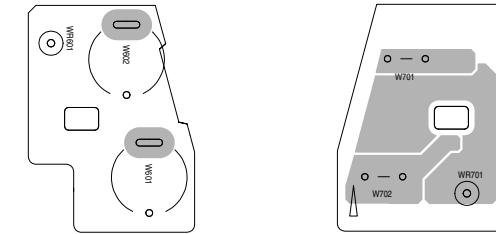

■ Rotary switch board

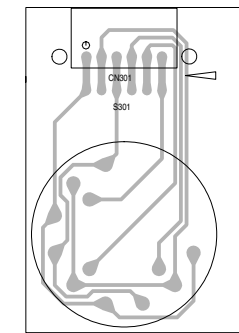

■ Volume board

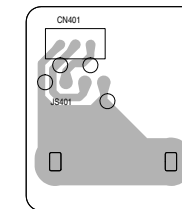

■ Modular jack board

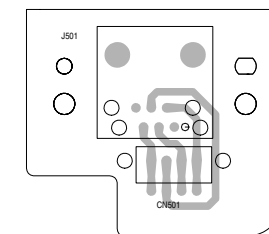

■ Main board (Reverse side)

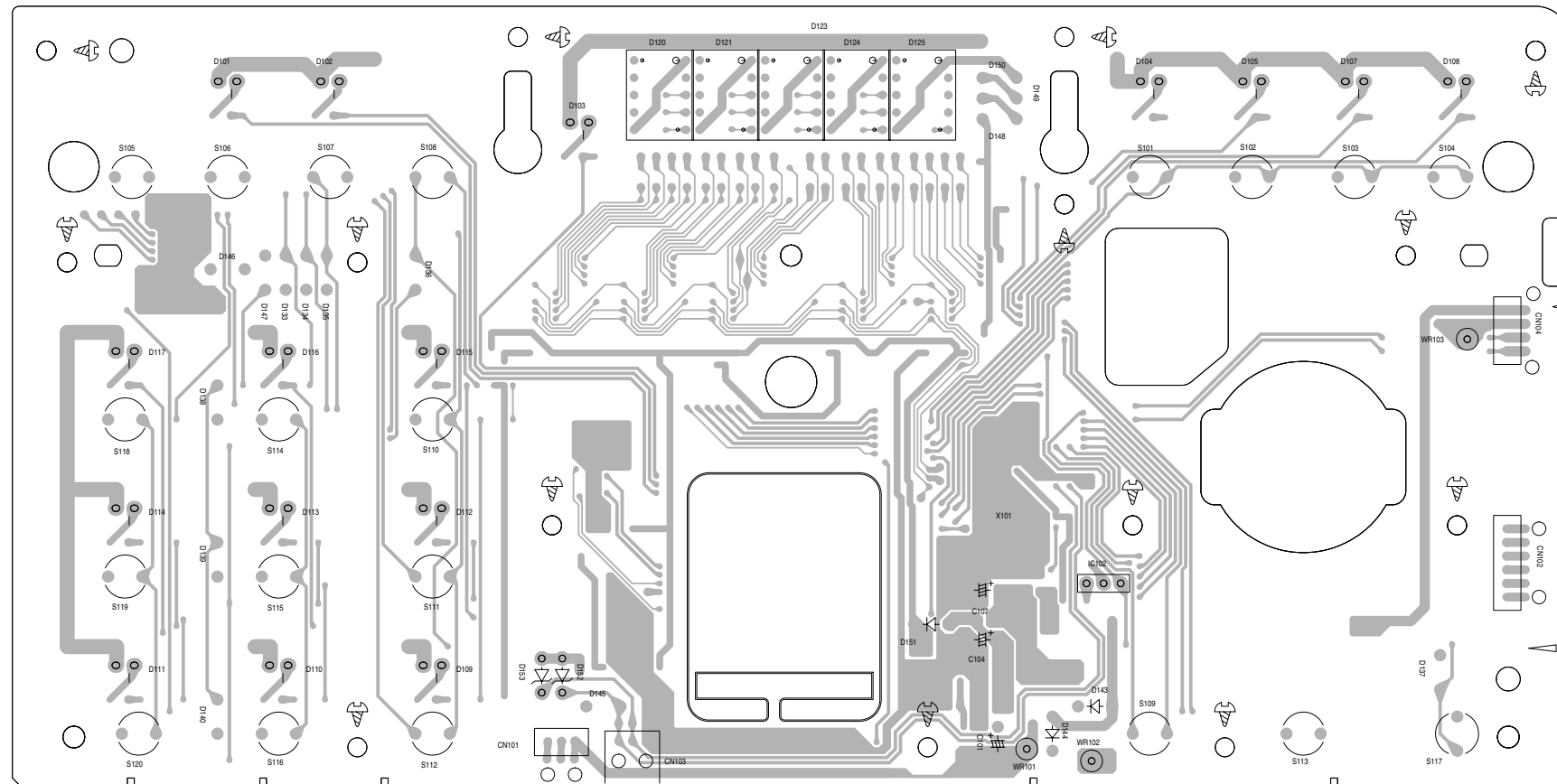

5

4

3

2

1

A

B

C

2-4

D

E

F

G

H

PARTS LIST

[RM-RE9000]

* All printed circuit boards and its assemblies are not available as service parts.

Area suffix

E ----- Continental Europe

- Contents -

Exploded view of general assembly and parts list	3-2
Electrical parts list	3-4
Packing materials and accessories parts list	3-6

Exploded view of general assembly and parts list

Block No. M 1 M M

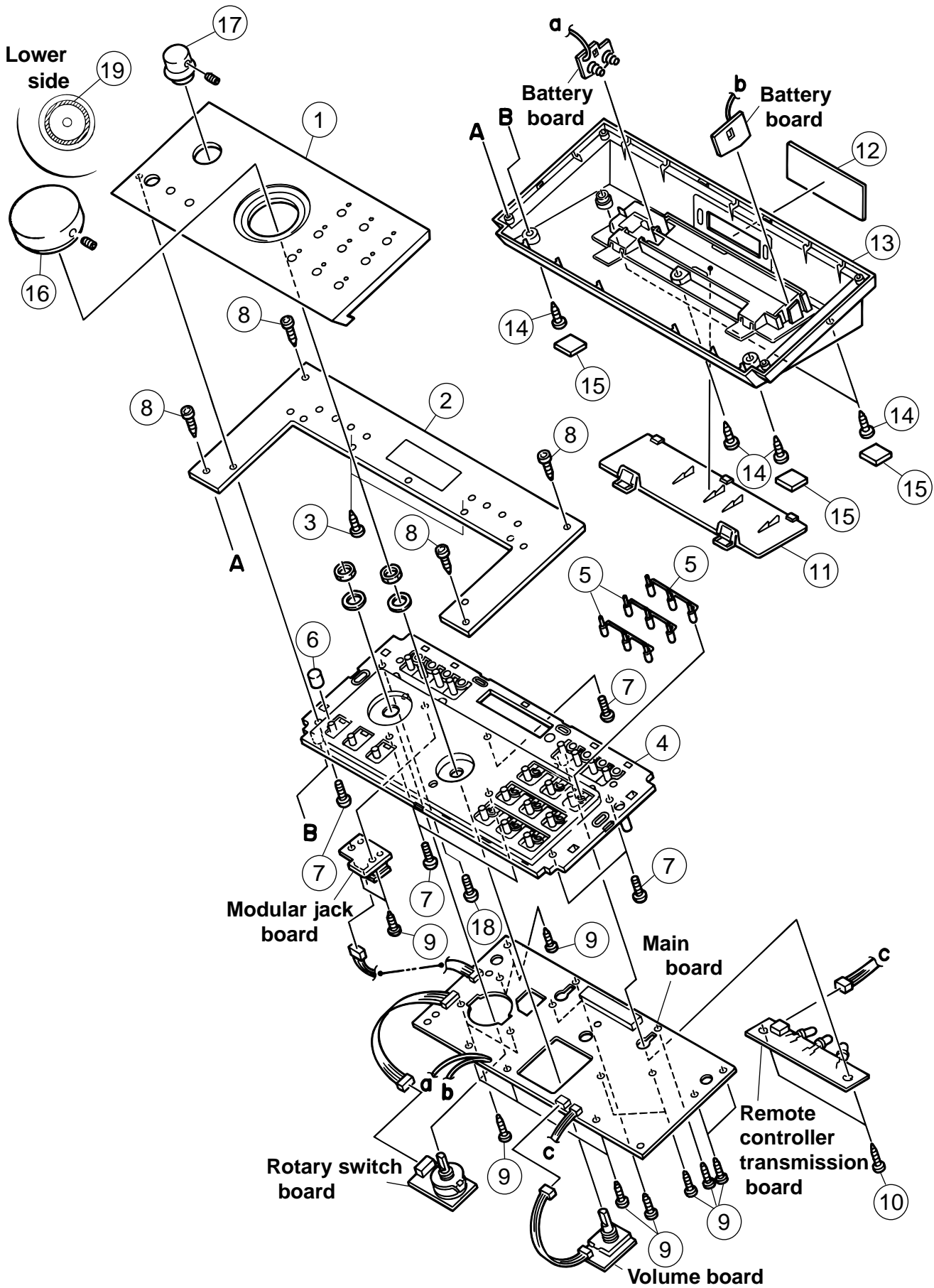

Parts list (General assembly)

Block No. M1MM

▲	Item	Parts number	Parts name	Q'ty	Description	Area
	1	LV20618-003A	TOP PANEL	1		
	2	LV20624-005A	LENS	1		
	3	QYSPSP3008M	SCREW	2	TOP-LENS	
	4	LV10323-002A	BASE	1		
	5	LV41482-001A	INDICATOR	3		
	6	LV41547-001A	CAP	1		
	7	QYSPSP3010Z	SCREW	6	TOP-BASE	
	8	LV40744-002A	SOCKET BOLT	4	LENS-BASE	
	9	QYSDSF2608Z	SCREW	16	C.B-BASE	
	10	QYSDSF2608Z	SCREW	2		
	11	LV20623-001A	BATT. COVER	1		
	12	LV41481-001A	REMOTE LENS	1		
	13	LV10322-002A	BOTTOM CASE	1		
	14	QYSBSF3010Z	SCREW	5	BOTTOM-BASE	
	15	E75896-001	FELT SPACER	4	BOTTOM CASE	
	16	LV31626-001A	VOL KNOB	1		
	17	LV31627-001A	SEL KNOB	1		
	18	QYSPSPL3012Z	SCREW	1	TOP-BASE	
	19	LV41797-001A	SPACER	1	VOL KNOB	

■ Electrical parts list (Main board)

Block No. 01

△	Item	Parts number	Parts name	Remarks	Area	△	Item	Parts number	Parts name	Remarks	Area
	C 101	QER60JM-476Z	E CAPACITOR	47MF 20% 6.3V			D 148	1SS133-T1	SI DIODE		
	C 102	NCF21EZ-104X	C CAPACITOR				D 149	1SS133-T1	SI DIODE		
	C 103	NCF21EZ-104X	C CAPACITOR				D 150	1SS133-T1	SI DIODE		
	C 104	QER60JM-476Z	E CAPACITOR	47MF 20% 6.3V			D 151	11E2-T5	DIODE		
	C 106	NCF21EZ-104X	C CAPACITOR				D 152	MTZJ6.8A-T2	ZENER DIODE		
	C 107	QER61AM-227Z	E CAPACITOR	220MF 20% 10V			D 153	MTZJ6.8A-T2	ZENER DIODE		
	C 108	NCF21CZ-155X	C CAPACITOR				D 201	SRZ-932C-22-T14	LED		
	C 109	NCF21CZ-155X	C CAPACITOR				D 202	SRZ-932C-22-T14	LED		
	C 110	NCF21CZ-155X	C CAPACITOR				D 203	SRZ-932C-22-T14	LED		
	C 111	NCF21CZ-155X	C CAPACITOR				D 701	RB160L-40-X	SB DIODE		
	C 112	NCF21CZ-155X	C CAPACITOR				D 702	RB160L-40-X	SB DIODE		
	C 113	NCF21CZ-155X	C CAPACITOR				IC101	MN101CP117	IC(MCU)		
	C 114	NCF21CZ-155X	C CAPACITOR				IC102	PST529G	IC		
	C 115	NCF21CZ-155X	C CAPACITOR				IC103	MAX1674EUA-X	IC		
	C 116	NCF21CZ-155X	C CAPACITOR				IC104	BU2114F-X	IC		
	C 118	NCF21CZ-155X	C CAPACITOR				IC105	BU2114F-X	IC		
	C 119	NCF21CZ-155X	C CAPACITOR				IC106	BU2114F-X	IC		
	C 120	NCF21CZ-155X	C CAPACITOR				IC107	BU2114F-X	IC		
	C 121	NCS21HJ-331X	C CAPACITOR				IC108	BU2114F-X	IC		
	C 122	NCS21HJ-331X	C CAPACITOR				IC109	BU2114F-X	IC		
	C 123	NCS21HJ-331X	C CAPACITOR				IC110	BU2114F-X	IC		
	C 124	NCS21HJ-331X	C CAPACITOR				IC111	TC74VHC123AF-X	IC		
	CN101	QJB002-031803	E-S-ID WIRE C-B				IC112	TC74VHC08F-X	IC		
	CN102	QJB002-060801	E-S-ID WIRE C-B				J 501	QNZ0004-001	MODULAR JACK		
	CN103	QGA2001F1-03	CONNECTOR				JS401	QSW0867-001	ROTARY ENCODER		
	CN104	QJB002-040904	E-S-ID WIRE C-B				L 101	NQL32CM-220X	INDUCTOR		
	CN201	QGA2001F1-03	CONNECTOR				Q 101	2SD1328/ST-X	TRANSISTOR		
	CN301	QGA2001F1-06	6P PLUG ASSY				Q 103	DTB113ZK-X	D TRANSISTOR		
	CN401	QJB002-030803	E-S-ID WIRE C-B				Q 104	DTC114YKA-X	D TRANSISTOR		
	CN501	QGA2001C1-04	4P PLUG ASSY				R 101	NRSA02J-221X	MG RESISTOR		
	D 101	SLR-342MC-T	LED				R 106	NRSA02J-105X	MG RESISTOR		
	D 102	SLR-342MC-T	LED				R 108	NRSA02J-103X	MG RESISTOR		
	D 103	SLR-342VC-T	LED				R 109	NRSA02J-103X	MG RESISTOR		
	D 104	SLR-342MC-T	LED				R 110	NRSA02J-121X	MG RESISTOR		
	D 105	SLR-342MC-T	LED				R 111	NRSA02J-121X	MG RESISTOR		
	D 107	SELU2E10C	LED				R 112	NRSA02J-331X	MG RESISTOR		
	D 108	SELU2E10C	LED				R 113	NRSA02J-121X	MG RESISTOR		
	D 109	SLR-342VC-T	LED				R 114	NRSA02J-121X	MG RESISTOR		
	D 110	SLR-342MC-T	LED				R 115	NRSA02J-331X	MG RESISTOR		
	D 111	SLR-342DC-T	LED				R 116	NRSA02J-331X	MG RESISTOR		
	D 112	SLR-342DC-T	LED				R 117	NRSA02J-561X	MG RESISTOR		
	D 113	SLR-342DC-T	LED				R 118	NRSA02J-221X	MG RESISTOR		
	D 114	SLR-342DC-T	LED				R 119	NRSA02J-271X	MG RESISTOR		
	D 115	SLR-342DC-T	LED				R 120	NRSA02J-271X	MG RESISTOR		
	D 116	SLR-342DC-T	LED				R 121	NRSA02J-271X	MG RESISTOR		
	D 117	SLR-342DC-T	LED				R 122	NRSA02J-271X	MG RESISTOR		
	D 120	LA-401VD	7 SEGMENT LED				R 123	NRSA02J-271X	MG RESISTOR		
	D 121	LA-401VD	7 SEGMENT LED				R 124	NRSA02J-271X	MG RESISTOR		
	D 123	LA-401VD	7 SEGMENT LED				R 125	NRSA02J-271X	MG RESISTOR		
	D 124	LA-401VD	7 SEGMENT LED				R 126	NRSA02J-331X	MG RESISTOR		
	D 125	LA-401VD	7 SEGMENT LED				R 127	NRSA02J-331X	MG RESISTOR		
	D 133	1SS133-T1	SI DIODE				R 128	NRSA02J-331X	MG RESISTOR		
	D 134	1SS133-T1	SI DIODE				R 129	NRSA02J-331X	MG RESISTOR		
	D 135	1SS133-T1	SI DIODE				R 130	NRSA02J-331X	MG RESISTOR		
	D 136	1SS133-T1	SI DIODE				R 131	NRSA02J-331X	MG RESISTOR		
	D 137	1SS133-T1	SI DIODE				R 132	NRSA02J-331X	MG RESISTOR		
	D 138	1SS133-T1	SI DIODE				R 133	NRSA02J-331X	MG RESISTOR		
	D 139	1SS133-T1	SI DIODE				R 134	NRSA02J-331X	MG RESISTOR		
	D 140	1SS133-T1	SI DIODE				R 135	NRSA02J-331X	MG RESISTOR		
	D 143	11E2-T5	DIODE				R 136	NRSA02J-331X	MG RESISTOR		
	D 145	1SS133-T1	SI DIODE				R 137	NRSA02J-331X	MG RESISTOR		
	D 146	1SS133-T1	SI DIODE				R 138	NRSA02J-331X	MG RESISTOR		
	D 147	1SS133-T1	SI DIODE				R 139	NRSA02J-331X	MG RESISTOR		

■ Electrical parts list (Main board)

Block No. 01

△	Item	Parts number	Parts name	Remarks	Area
	R 140	NRSA02J-331X	MG RESISTOR		
	R 141	NRSA02J-331X	MG RESISTOR		
	R 142	NRSA02J-331X	MG RESISTOR		
	R 143	NRSA02J-331X	MG RESISTOR		
	R 144	NRSA02J-331X	MG RESISTOR		
	R 145	NRSA02J-331X	MG RESISTOR		
	R 146	NRSA02J-331X	MG RESISTOR		
	R 147	NRSA02J-331X	MG RESISTOR		
	R 148	NRSA02J-331X	MG RESISTOR		
	R 149	NRSA02J-331X	MG RESISTOR		
	R 150	NRSA02J-331X	MG RESISTOR		
	R 151	NRSA02J-331X	MG RESISTOR		
	R 152	NRSA02J-331X	MG RESISTOR		
	R 153	NRSA02J-331X	MG RESISTOR		
	R 154	NRSA02J-331X	MG RESISTOR		
	R 155	NRSA02J-331X	MG RESISTOR		
	R 156	NRSA02J-331X	MG RESISTOR		
	R 157	NRSA02J-331X	MG RESISTOR		
	R 158	NRSA02J-331X	MG RESISTOR		
	R 159	NRSA02J-331X	MG RESISTOR		
	R 160	NRSA02J-331X	MG RESISTOR		
	R 161	NRSA02J-331X	MG RESISTOR		
	R 162	NRSA02J-331X	MG RESISTOR		
	R 163	NRSA02J-331X	MG RESISTOR		
	R 164	NRSA02J-331X	MG RESISTOR		
	R 165	NRSA02J-331X	MG RESISTOR		
	R 166	NRSA02J-223X	MG RESISTOR		
	R 167	NRSA02J-223X	MG RESISTOR		
	R 168	NRSA02J-223X	MG RESISTOR		
	R 169	NRSA02J-223X	MG RESISTOR		
	R 170	NRSA02J-223X	MG RESISTOR		
	R 171	NRSA02J-223X	MG RESISTOR		
	R 172	NRSA02J-223X	MG RESISTOR		
	R 173	NRSA02J-223X	MG RESISTOR		
	R 175	NRSA02J-102X	MG RESISTOR		
	R 176	NRSA02J-0R0X	MG RESISTOR		
	R 179	NRSA02J-223X	MG RESISTOR		
	R 180	NRSA02J-223X	MG RESISTOR		
	R 181	NRSA02J-223X	MG RESISTOR		
	R 182	NRSA02J-223X	MG RESISTOR		
	R 183	NRSA02J-223X	MG RESISTOR		
	R 184	NRSA02J-682X	MG RESISTOR		
	R 185	NRSA02J-223X	MG RESISTOR		
	R 186	NRSA02J-103X	MG RESISTOR		
	R 189	NRSA02J-103X	MG RESISTOR		
	R 201	NRSA02J-3R9X	MG RESISTOR		
	R 202	NRSA02J-3R9X	MG RESISTOR		
	R 203	NRSA02J-3R9X	MG RESISTOR		
	S 101	QSW0802-001Z	TACT SWITCH		
	S 102	QSW0802-001Z	TACT SWITCH		
	S 103	QSW0802-001Z	TACT SWITCH		
	S 104	QSW0802-001Z	TACT SWITCH		
	S 105	QSW0802-001Z	TACT SWITCH		
	S 106	QSW0802-001Z	TACT SWITCH		
	S 107	QSW0802-001Z	TACT SWITCH		
	S 108	QSW0802-001Z	TACT SWITCH		
	S 109	QSW0802-001Z	TACT SWITCH		
	S 110	QSW0802-001Z	TACT SWITCH		
	S 111	QSW0802-001Z	TACT SWITCH		
	S 112	QSW0802-001Z	TACT SWITCH		
	S 113	QSW0802-001Z	TACT SWITCH		
	S 114	QSW0802-001Z	TACT SWITCH		
	S 115	QSW0802-001Z	TACT SWITCH		

△	Item	Parts number	Parts name	Remarks	Area
	S 116	QSW0802-001Z	TACT SWITCH		
	S 117	QSW0802-001Z	TACT SWITCH		
	S 118	QSW0802-001Z	TACT SWITCH		
	S 119	QSW0802-001Z	TACT SWITCH		
	S 120	QSW0802-001Z	TACT SWITCH		
	S 301	QSW0864-001	ROTARY SWITCH		
	W 601	VYH7199-001	BATTERY SPRING		
	W 602	VYH7199-001	BATTERY SPRING		
	X 101	QAX0246-001Z	RESONATOR		

Packing materials and accessories parts list

Block No.

M	2	M	M
---	---	---	---

Block No.

M	3	M	M
---	---	---	---

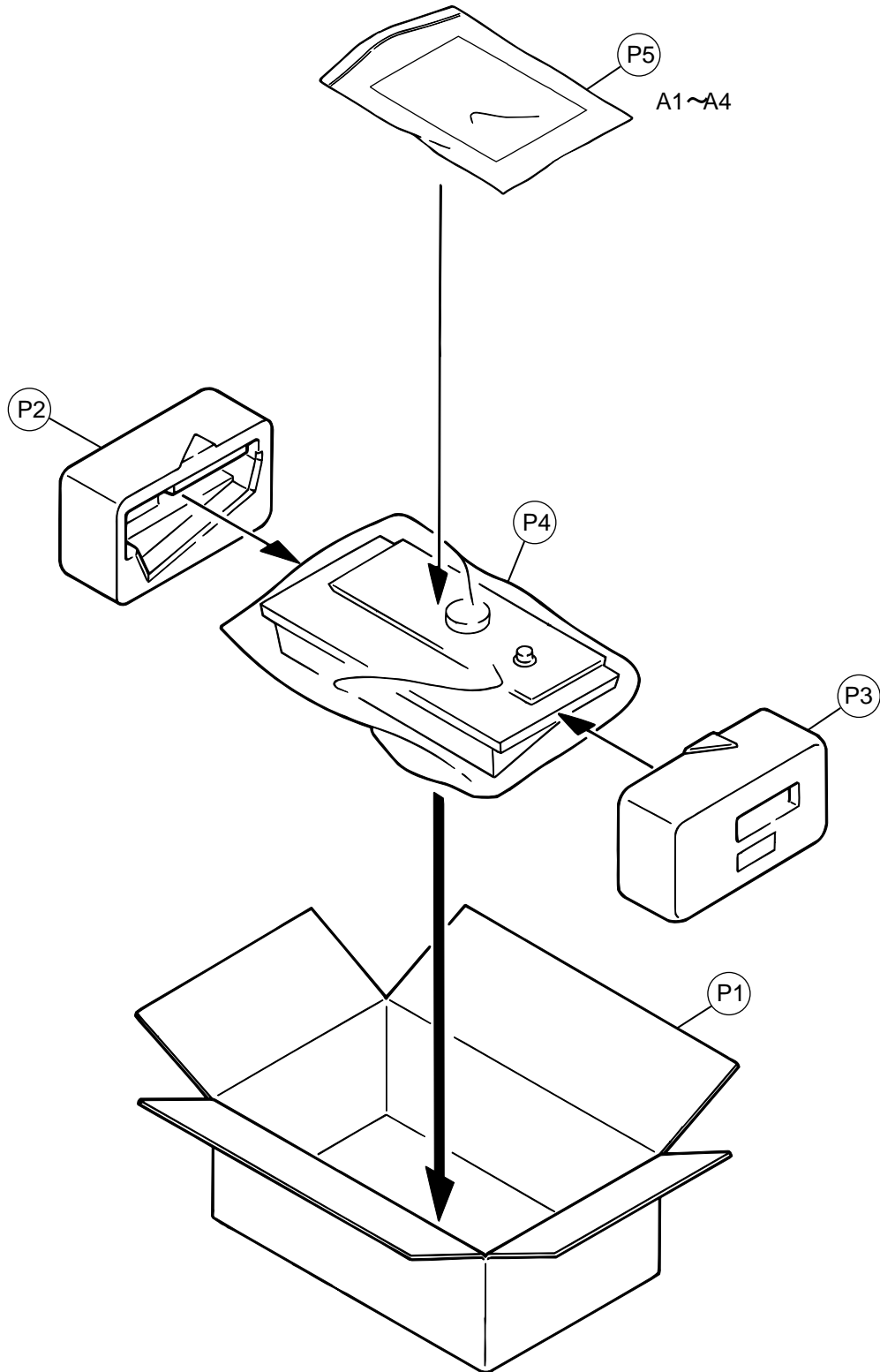

Parts list (Packing)

Block No. M2MM

△	Item	Parts number	Parts name	Q'ty	Description	Area
	P 1	LV31629-002A	CARTON BOX	1		
	P 2	LV31630-001A	CUSHION(L)	1		
	P 3	LV31631-001A	CUSHION(R)	1		
	P 4	QPC02204515	POLY BAG	1	FOR SET	
	P 5	QPB01702404P	POLY BAG	1	FOR INST	

Parts list (Accessories)

Block No. M3MM

△	Item	Parts number	Parts name	Q'ty	Description	Area
	A 1	LVT0653-001A	INST.BOOK	1	ENG	
	A 2	-----	AL BATTERY	2		
	A 3	QPH01501510	SHEET	1	AL BATTERY	
	A 4	BT-54013-2	W.CARD	1		

JVC

VICTOR COMPANY OF JAPAN, LIMITED

AUDIO & COMMUNICATION BUSINESS DIVISION

PERSONAL & MOBILE NETWORK BUSINESS UNIT. 10-1,1chome,Ohwatari-machi,Maebashi-city,371-8543,Japan

JVC

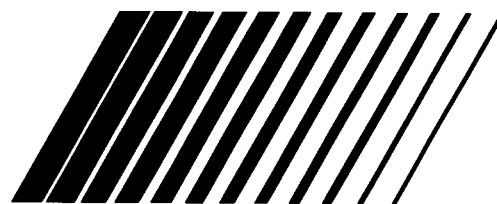

SYSTEM CONTROLLER

RM-RE9000

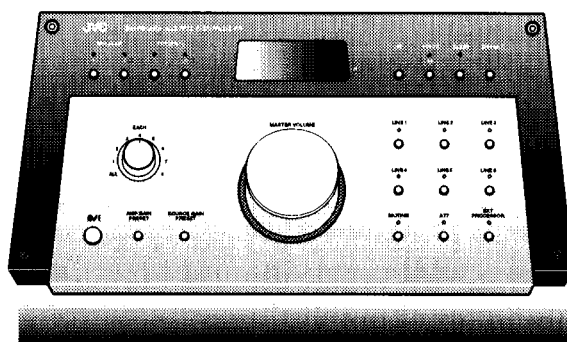

INSTRUCTIONS

For Customer Use:

Enter below the Model No. and Serial No. which are located either on the rear, bottom or side of the cabinet. Retain this information for future reference.

Model No. _____

Serial No. _____

LVT0653-001A

[E]

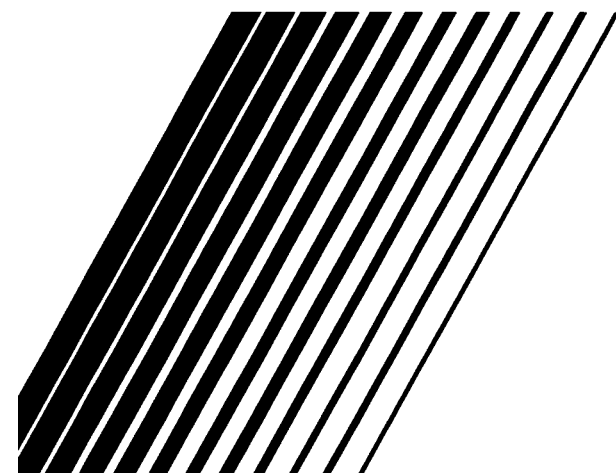

Warnings, Cautions and Others

Handle batteries properly.

To avoid battery leakage or explosion:

- Remove batteries when the Remote Control will not be used for a long time.
- When you need to replace the batteries, replace all batteries at the same time with new ones.
- Don't use an old battery with a new one.
- Don't use different types of batteries together.

Contents

Warnings, Cautions and Others	2	Basic Operations	8
Features	3	Basic control	8
Setting up the Remote Control	4	Setting the AMP GAIN PRESET	9
Putting batteries in the remote control	4	Setting the SOURCE GAIN PRESET	10
Connections	5	Using the sleep function	11
Making connections with a communication cable	5	Specification	12
Switches, Buttons, and Controls	6	Dimension	12
		Troubleshooting	13
		Memo	14

Features

High precision wireless control of the AX-M9000 amplifier (sold separately) (Wired system control also possible)

In conjunction with the monaural integrated amplifier, this unit can be used for highly responsive multi channel and multi amplifier media playback. The RM-RE9000 system controller is designed for use with multiple amplifier configurations. From high-precision gain control onward, all of the amplifier controls can be performed using this unit.

Capable of controlling up to 8 channels at the same time, or the mode can be changed to control each channel individually

Consolidating the control of amplifiers for up to 8 channels, singular control is also possible. Additionally, it is possible to adjust the preset gain settings etc., and other diverse settings for each amplifier.

Realization of the appearance and control of the front panel of a high end control amplifier

JVC has pursued the feel of the control and the capabilities of a high quality preamplifier in our design of this unit.

Setting up the Remote Control

Both “wireless” and “wired” control are possible with this unit.
The following explanation is for wireless control.

- When using this unit for wireless control, it is necessary to put batteries in the remote control.
- When setting up for wired control, do not insert batteries in the unit because the power is supplied from the AX-M9000.

Putting batteries in the remote control

- Use only alkaline batteries.
- Do not mix different types of batteries or mix partially used batteries with new batteries.
- When not using the remote control for long periods of time, remove the batteries to avoid leakage.
- When the range of the remote control starts to drop, replace all batteries.
- The life of the batteries is about one month.

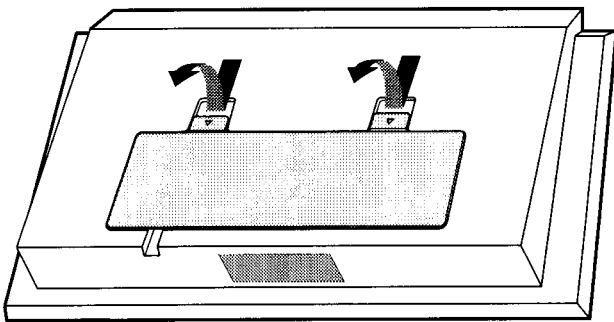

- 1 On the back of the remote control, push the two levers in the direction of the arrows and pull out to remove the rear compartment cover.

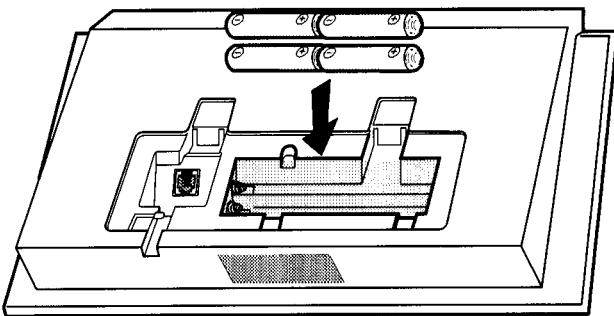

- 2 Insert the batteries making sure to observe the proper polarity: (+) to (+) and (-) to (-).
(Make sure that the batteries are inserted all the way.)

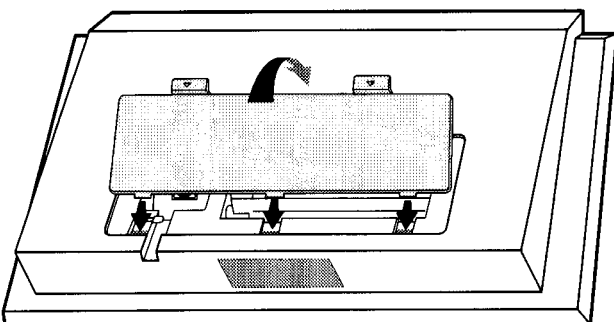

- 3 Insert the three tabs of the cover into the slots on the rear panel first and then close the cover.
(When the 2 levers click into place, the cover is closed.)

Connections

Both “wireless” and “wired” control are possible with this unit.
The following explanation is for wired control.

- When setting up for wired control, do not insert batteries in the unit because the power is supplied from the AX-M9000.
- When making connections, make sure that the power of the AX-M9000 is off.

Making connections with a communication cable

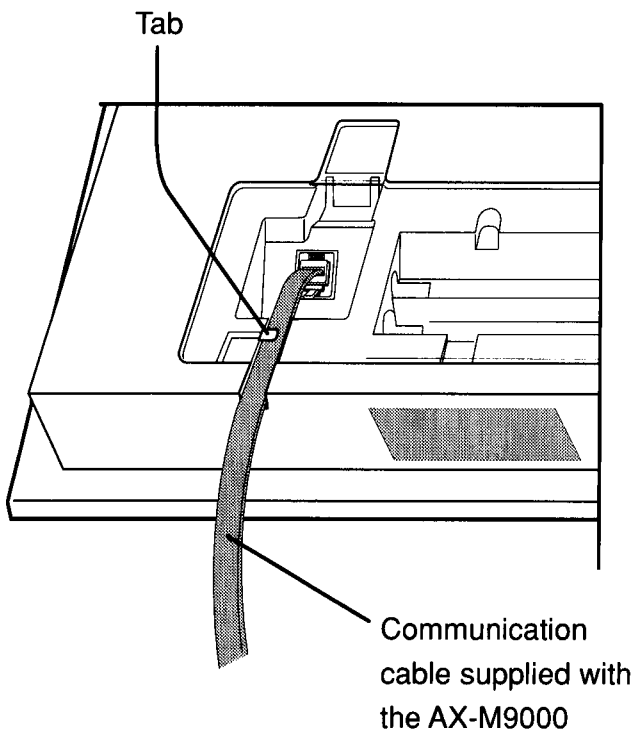

- 1 Remove the rear compartment cover.**
See page 4 for details regarding opening and closing the rear compartment cover.
- 2 Connect the communication cable.**
Use the communication cable supplied with the AX-M9000.
(It is also possible to use a commercially available 6-pin 4-conductor modular cable.)
- 3 Secure the cable under the tab.**
- 4 Close the rear compartment cover.**

Make connections to the COMMUNICATION JACKS IN jack of the AX-M9000.

(Also refer to the instructions supplied with the AX-M9000.)

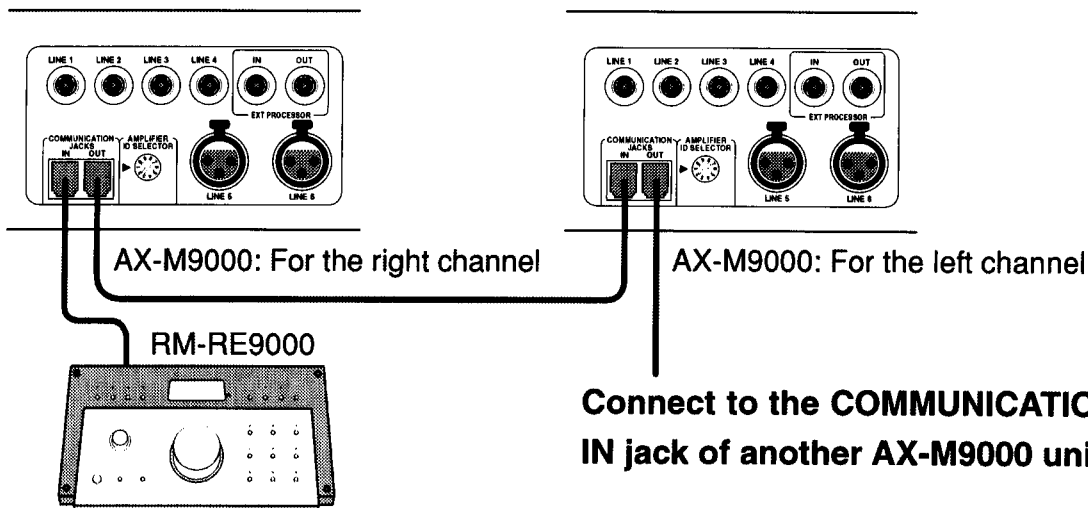

Switches, Buttons, and Controls

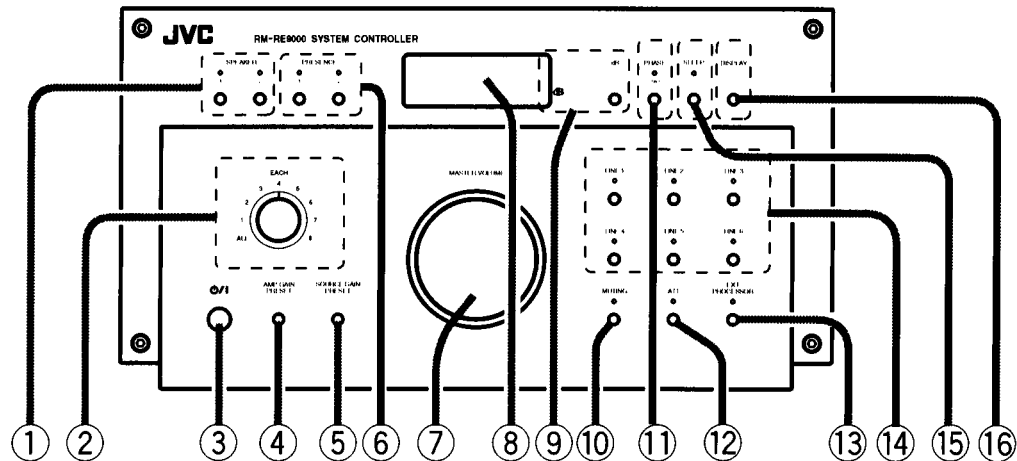

① SPEAKER buttons / indicators

- "1" indicator is lit: The speaker connected to speaker terminal 1 is selected.
- "2" indicator is lit: The speaker connected to terminal 2 is selected.
- "1" and "2" indicators are lit: The both speakers connected to speaker terminal 1 and 2 are selected.
- No indicator is lit: No speaker is selected.

② EACH dial

- Select for control of a single AX-M9000 amplifier or for simultaneous control of all of the connected AX-M9000 amplifiers.
- ALL: Select all of the AX-M9000 amplifiers connected in the series.
- 1 - 8: Select the ID number of each AX-M9000 independently.

③ ⏻/I button

- Display is lit: Power is on.
- Display is not lit: Power is in standby.

④ AMP GAIN PRESET button

- Use to preset the gain of each ID number of the AX-M9000 in the range of -9.5 dB to $+9.5$ dB in 0.5 dB steps.

⑤ SOURCE GAIN PRESET button

- Use to preset the gain of each of the components connected to the LINE inputs (1 to 6) of the AX-M9000 in the range of -9.5 dB to $+9.5$ dB in 0.5 dB steps.

⑥ PRESENCE buttons / indicators

- Boosts the lower frequencies to give a greater feeling of "being there".
- "1" indicator is lit: The lower frequencies are boosted. There is a 3 dB level increase at 50 Hz.
- "2" indicator is lit: The lower frequencies are boosted. There is a 4 dB level increase at 70 Hz.

⑦ MASTER VOLUME control

- Use to adjust the volume.
- Use to adjust the AMP GAIN and SOURCE GAIN levels.

⑧ Display

- Displays the volume level in decibels (dB) or percent (%). Use the dB button to switch the display.
- When adjusting the GAIN preset, the display appears in decibels (dB).

⑨ dB button / indicator

- Use the dB button to switch the display.
- dB indicator is lit: The absolute volume is displayed in decibels (dB).
- dB indicator is not lit: The relative volume is displayed as a percentage (Min. to Max.).

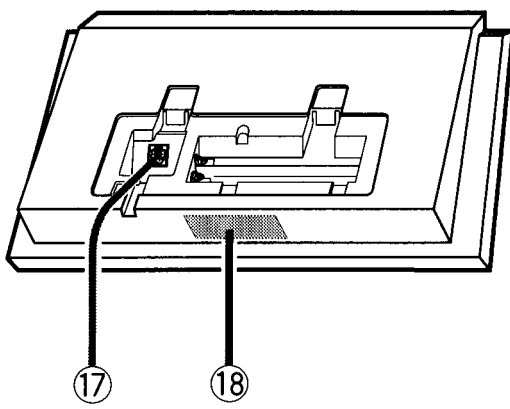

During wireless control, the indicator lights go out after approximately 10 seconds. To turn on the indicators again, press the DISPLAY button or another function button.

⑩ MUTING button / indicator

Indicator is lit: The volume is reduced to the absolute minimum.
 Indicator is not lit: The volume is restored to its former level.

⑪ PHASE button / indicator

Indicator is lit: The phase of the input and output is reversed.
 Indicator is not lit: The phase of input and output is the same.

⑫ ATT button / indicator

When a large input is encountered, it is possible to reduce the signal strength.
 Indicator is lit: The gain of the input amplifier is lowered by 12 dB.
 Indicator is not lit: The function is off.

⑬ EXT PROCESSOR button / indicator

Indicator is lit: Selects the component connected to the EXT PROCESSOR jacks of the AX-M9000.
 Indicator is not lit: The function is off.

⑭ LINE buttons / indicators

- Use to select the source.
- Only one of the LINE 1 to 6 indicators light up according to the selected line number.

⑮ SLEEP button / indicator

Indicator is lit: The sleep function is on.
 Indicator is not lit: The sleep function is off.
 For operation, see page 11.

⑯ DISPLAY button

Press and hold the DISPLAY button for about 2 seconds to darken the display.
 Press and hold the DISPLAY button once again for about 2 seconds to restore the display illumination.
 The display of the AX-M9000 also changes in the same way.

⑰ COMMUNICATION jack

This jack is used for making connection to an AX-M9000 amplifier (sold separately). It is also possible to use a commercially available JVC modular cable (6-pin 4-conductor, not to exceed 10 meters in length).

⑱ Remote control transmitter

When using this unit for wireless control, point the transmitter at the remote sensor of the AX-M9000.

Basic Operations

Basic control

- When using this unit in the wireless configuration, point this unit to the AX-M9000.
- When using this unit in the wired configuration, it can be pointed to any direction.
- When this unit is used in the wireless configuration, the response of the AX-M9000 becomes slightly slower. The display turns off in 10 seconds after operation in order to reduce battery consumption.
- The ID number of the controlled AX-M9000 can be specified using the EACH dial.

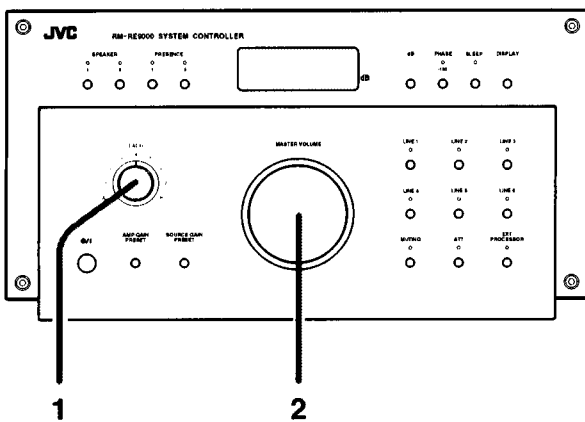

1 Select the amplifier using the EACH dial.

Select the ID number of the connected AX-M9000. When the EACH dial is set to ALL, all of the AX-M9000 units can be controlled simultaneously.

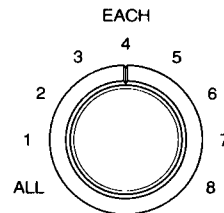

2 Set the functions for each AX-M9000 amplifier.

Press the LINE 1-6 buttons to select the source, adjust the volume with the MASTER VOLUME control, etc.

Refer to “Parts and Their Functions” on page 6.

Note:

- Even when a setting is changed on the control panel of the AX-M9000, the change is not applied to the setting of this unit.

Setting the AMP GAIN PRESET

- Settings can be made for up to 8 AX-M9000 units.
- When controlling the overall volume, you can preset the difference in gain for each ID number of the AX-M9000 independently.
- This function is convenient for setting the volume level of each ID number of speakers in a multi channel speaker system.
- Both “wireless” and “wired” control are possible with this unit. Select the type of control corresponding to how the unit is going to be used.

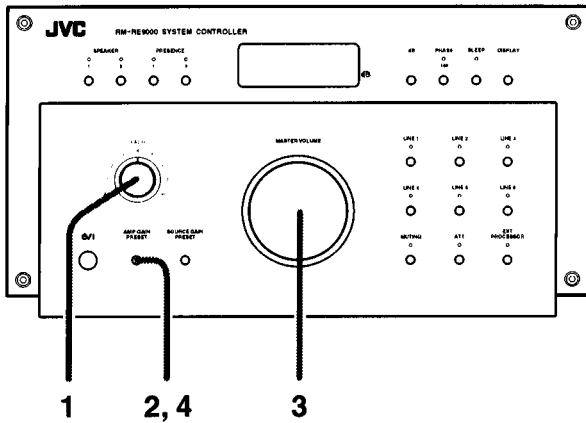

1 Turn the EACH dial to select an amplifier.

Select the ID number of the connected AX-M9000.

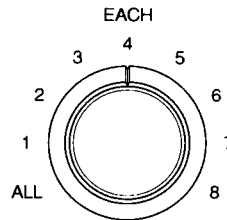

2 Press the AMP GAIN PRESET button.

AMP GAIN
PRESET



3 Adjust the MASTER VOLUME control.

The volume can be adjusted from -9.5 dB to +9.5 dB.

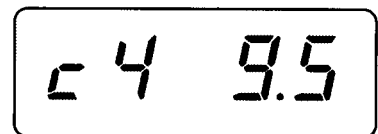
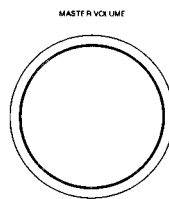

Sample display

4 Press the AMP GAIN PRESET button again.

AMP GAIN
PRESET



Notes:

- AMP GAIN PRESET cannot be adjusted when the EACH dial is set to ALL.
- The value of AMP GAIN PRESET is not reflected in the volume value shown in the display.

Setting the SOURCE GAIN PRESET

- Settings can be made for up to 8 AX-M9000 units.
- When controlling the overall volume, you can preset the difference in input volume between lines.
- This feature is convenient for correcting the differences in input volume between lines.
- Both “wireless” and “wired” control are possible with this unit. In this section, use the information corresponding to how the unit is going to be used.

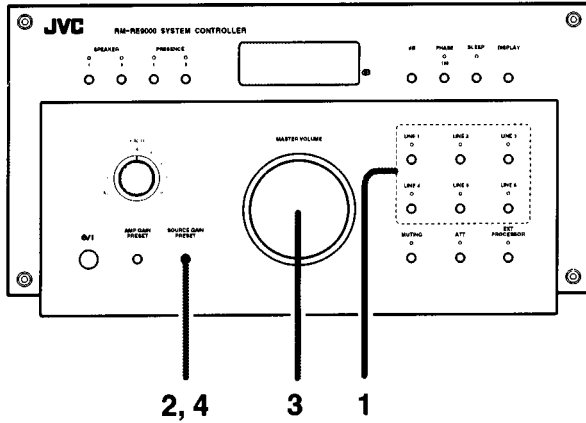

1 Select the appropriate LINE button.

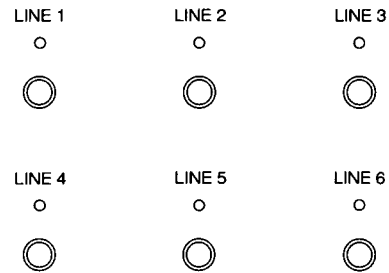

2 Press the SOURCE GAIN PRESET button.

SOURCE GAIN
PRESET



3 Adjust the MASTER VOLUME control.

The volume can be adjusted from -9.5 dB to $+9.5$ dB.

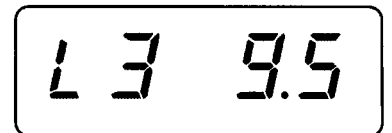
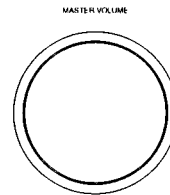

Sample display

4 Press the SOURCE GAIN PRESET button again.

SOURCE GAIN
PRESET



Note:

- The value of SOURCE GAIN PRESET is not reflected in the volume value shown in the display.

Using the sleep function

The SLEEP button enables you to set the AX-M9000 and other components connected by means of a communication cable to turn off automatically after a specified time period.

Press the SLEEP button to light the indicator.



- When the SLEEP key is pressed, the display shows "00". (The display of the AX-M9000 also becomes identical.)
- Each press of the key switches the set time (in minute) as shown below. (The same occurs also at the AX-M9000.)

→ 00 → 10 → 20 → 30 → 40 → 50 → 60 → 70 → 80 → 90

- When the set time has elapsed, the AX-M9000 is turned off automatically.
- The components connected through communication cables are turned off in the interlocked operation. (It is not possible to perform the setting for a single component.)
- While the sleep function is enabled, you can press the SLEEP button to see how much time is left. To cancel the sleep function, press the SLEEP button until the SLEEP indicator disappears.
- When "wired" connection is applied, the RM-RE9000 is also turned off automatically when the set time has elapsed. (The displayed elapsed time and the power OFF timing of the RM-RE9000 may be different from those of the AX-M9000.)
- When "wireless" operation is used, the elapsed time is not displayed and the display is not turned off on the RM-RE9000. When the display is switched on again after it has turned off automatically in 10 seconds, the set time display on the RM-RE9000 is reset to the initial condition. (The setting of the AX-M9000 does not change until the time is set again.)
- When the AX-M9000 is turned off automatically by the SLEEP function during "wireless" operation, the RM-RE9000 is not turned off automatically (STANDBY mode). As a result, when turning the AX-M9000 the next time, it is required to press the POWER button to turn the RM-RE9000 off then press the POWER button again to turn it on (i.e. press the POWER button twice).

Specification

Transmission system: Infrared system
Wired system

Power requirements : Wireless system: DC 3 V (power supplied from batteries)
Wired system: DC 5.6 V (power supplied from AX-M9000)

Mass : 1.0 kg (including batteries)
0.9 kg (not including batteries)

Accessories : AA (15F), LR6, alkaline dry batteries (to check operation of remote control) (4)

Dimension

Unit of measurement: mm

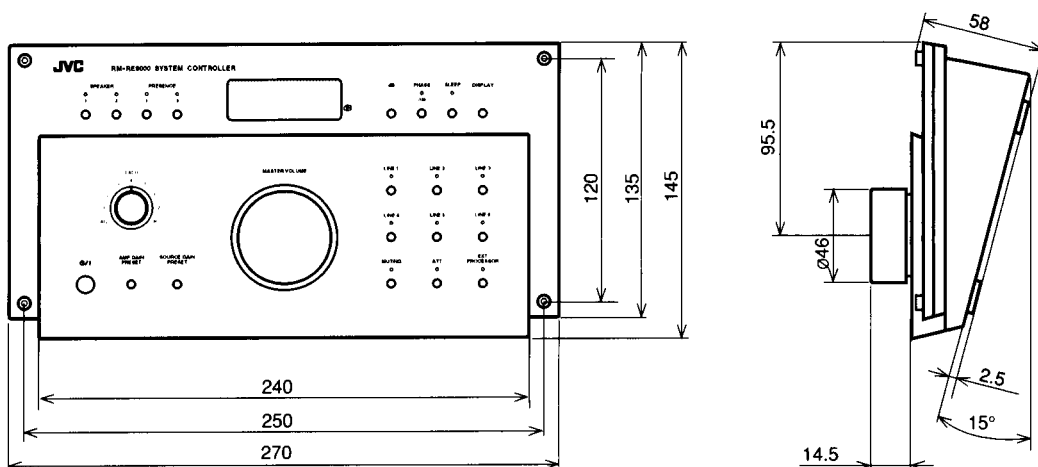

Design and specifications of this unit are subject to change without notice.

Troubleshooting

Remote control does not work

- When the POWER button is pressed, but the display does not light, replace the batteries.
- Make sure the EACH dial is set in a position that corresponds to the ID number of at least one of the AX-M9000 amplifiers.
- Check that the communication cable is connected correctly.

Memo

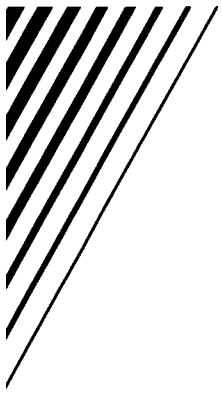

JVC
VICTOR COMPANY OF JAPAN, LIMITED